

Elastomeric Panel Isolators

for Aircraft Interiors

Lord elastomeric panel isolators control noise and high frequency vibration in a broad range of aircraft interior applications. These high-performance devices offer superior performance over the traditional hard elastomeric puck isolators commonly installed in aircraft. Lord elastomeric isolators feature the latest in design and material technology. The improved level of cabin comfort they achieve translates into higher customer satisfaction and fewer complaints.

Features & Benefits

- Tuned performance to isolate noise and vibration
- Marked improvement over common hard elastomer puck designs
- Low height profile
- Failsafe design with interlocking metal components
- Interchangeability with existing interior isolator designs
- All-Attitude performance (1:1 Axial to Radial stiffness)
- Offered in multiple stiffness levels to optimize performance in various applications
- Consistent performance over a broad temperature range with silicone elastomer

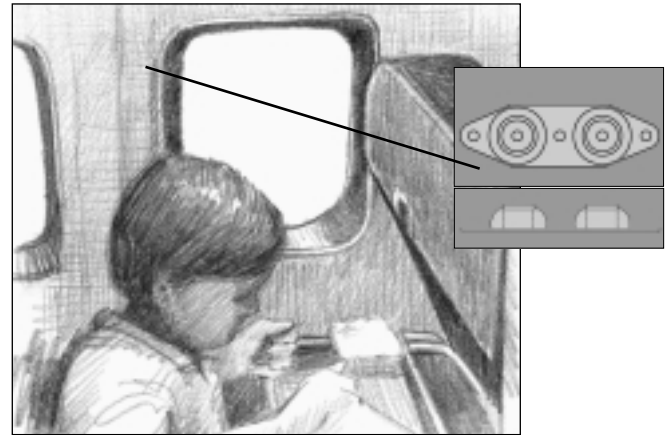
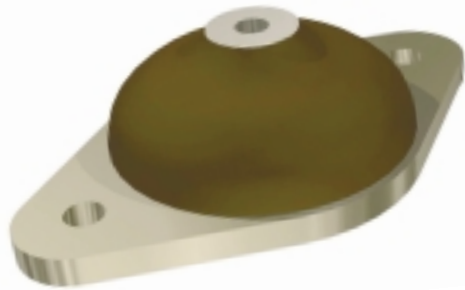

Typical Applications

- Ceiling Panels
- Dado Panels
- Sidewall Panels
- Bulkheads
- Crew Rests
- Interior Trim and Door Panels
- Entertainment and Audio Equipment
- Sensitive Equipment
- Galley and Lavatory



LORD

Lord Panel and Interior Isolators

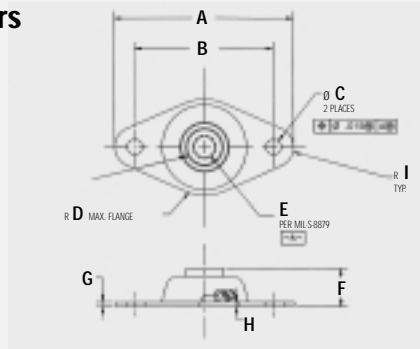

FIG. 1

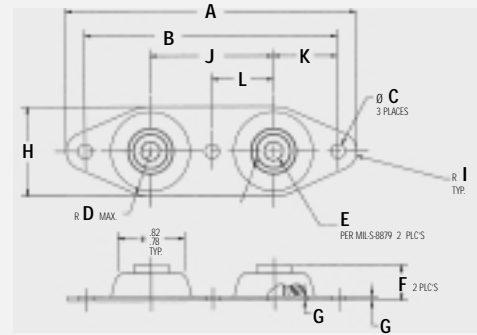

FIG. 2

Part No.	Material	Fig.	A in [mm]	B in [mm]	C in [mm]	D in [mm]	E	F in [mm]	G in [mm]	H in [mm]	I in [mm]	J in [mm]	K in [mm]	L in [mm]	Rated Load lbs [Kg]	Axial Static Stiffness lbs/in [N/mm]	Ult. Load lbs [Kg]	Fail-Safe Y/N
J-23676-1	Alum. Alloy Carbon Steel Silicone Elast.	1	1.61 [40.9]	1.25 [31.8]	0.14 [3.5]	0.43 [10.9]	#10-32 UNJF 3B THD	0.34 [8.6]	0.04 [1.0]	0.04 [1.0]	0.18 [4.6]				1 to 4 [0.45 to 1.81]	250 [44]	100 [45.35]	Yes
J-23676-2	Alum. Alloy Carbon Steel Silicone Elast.	2	2.79 [70.9]	2.4 [61.0]	0.14 [3.5]	0.43 [10.9]	#10-32 UNJF 3B THD	0.34 [8.6]	0.04 [1.0]	0.866 [22.0]	0.18 [4.6]	1.18 [30.0]	0.61 [15.5]	0.59 [15.0]	4 to 8 [1.81 to 3.62]	600 [105]	200 [90.70]	Yes
J-23644-4	Alum. Alloy Chromate Conv. Coated Silicone Elast.	1	1.86 [47.2]	1.5 [38.1]	0.17 [4.3]	0.6 [15.2]	0.2 [5.1]	0.33 [8.2]	0.05 [1.3]	0.05 [1.3]	0.18 [4.6]				5 to 10 [2.26 to 4.53]	500 [88]	150 [68.04]	Yes

Note: These are Lord's standard panel and interiors isolators. Lord can also formulate custom elastomers to meet special requirements including low smoke/toxicity, chemical resistance and specific modulus and/or damping factor. Standard metric sizes are also available. If you do not find the exact product you need listed above, please contact us to discuss how we can provide a product that more exactly fits your application.

Proven Solutions

From our first rubber-to-metal engine mount in the 1930s to today's advanced active control systems, Lord Corporation has developed real-world solutions for the aerospace industry's toughest problems. In addition to our standard products, we develop custom, high-performance products for military and commercial applications on aircraft, spacecraft, ships and ground vehicles. Customers rely on our expertise in:

- Acoustic and vibration problem diagnosis
- Dynamic vibration and noise testing
- Product design, development and manufacturing
- Complete system optimization

Lord products are available around the world through a service and support network that includes offices throughout North America, Europe and Asia.

Lord Corporation Mechanical Products Division

2000 West Grandview Blvd.
P.O. Box 10038
Erie, PA 16514-0038
Tel: 814/868-5424
Toll Free: 877/494-0399
Fax: 814/864-3452
www.lordmpd.com

International Offices:

Lord S. A.
Immeuble Strategy Ctr.
10 Rue des Gaudines
F78100 Saint Germain-en-Laye
France
Tel: +33 (1) 3087-0578
Fax: +33 (1) 3087-0827

Lord Singapore
1 Marine Parade Central
#13-01 Parkway Centre
Singapore 449408
Tel: +65-346-3082
Fax: +65-348-6928